

TECHNICAL DATA/SPECIFICATION

MODEL: SRE-3000 ELAN STRAIGHT RAIL STAIRLIFT, PRIVATE RESIDENCE ONLY

RATED LOAD: 300 LBS, ONE PASSENGER

POWER SOURCE: 24 VOLT DC COMPRISED OF (2) 3 AMP/HR
12 VOLT SEALED BATTERIES
105-230 VOLT AC 0.6 AMP, 24 VOLT DC 1 AMP
CONTINUOUS MONITORING CHARGER.

DRIVE: 24 VOLT DC DIRECT DRIVE SELF LOCKING POSITIVE GEARED MOTOR,
2 POLE RATED .18 HP MAX., RIGHT ANGLE WORM GEARBOX,
50Nm (442in.lb.) TORQUE MAX., 25.5 RPM SPEED MAX.,
16 AMP CURRENT MAX.

SUSPENSION: RACK & PINION - INTEGRATED 8DP GEAR RACK
ON RAIL WITH SPUR GEAR ON THE OUTPUT SHAFT
OF GEARBOX.

BRAKING: DYNAMIC MOTOR BRAKING THROUGH THE MOTOR
CONTROLLER, WORM GEAR, ELECTRO-MECHANICAL
MOTOR BRAKE AND OVERSPEED PROTECTION.

CONTROLS: CONTINUOUS PRESSURE ROCKER SWITCH LOCATED
ON THE ARMREST AND WALL MOUNTED CALL/SEND
CONTROLS LOCATED AT BOTH THE TOP AND BOTTOM
LANDINGS.

ANGLES: 22 TO 45 DEGREES (SPECIALS UP TO 52 DEGREES),
RIGHT OR LEFT HAND ORIENTATIONS.

FINAL LIMIT SWITCH: STANDARD

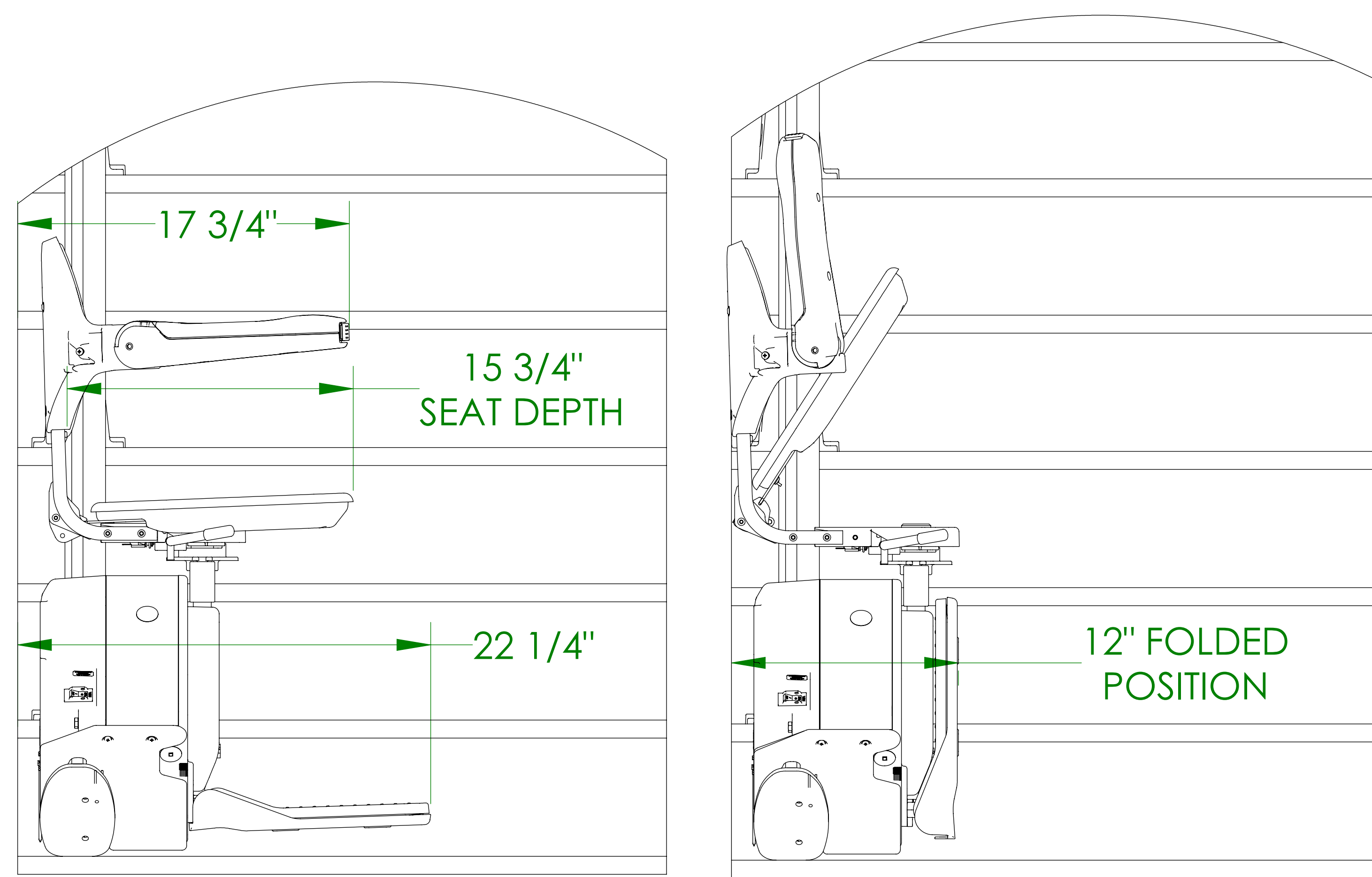

SIDE VIEWS

DIMENSIONS SHOWN IN SIDE VIEWS
ARE BASED ON 4-1/2" RAIL POSITION
FROM WALL OR OBSTRUCTION

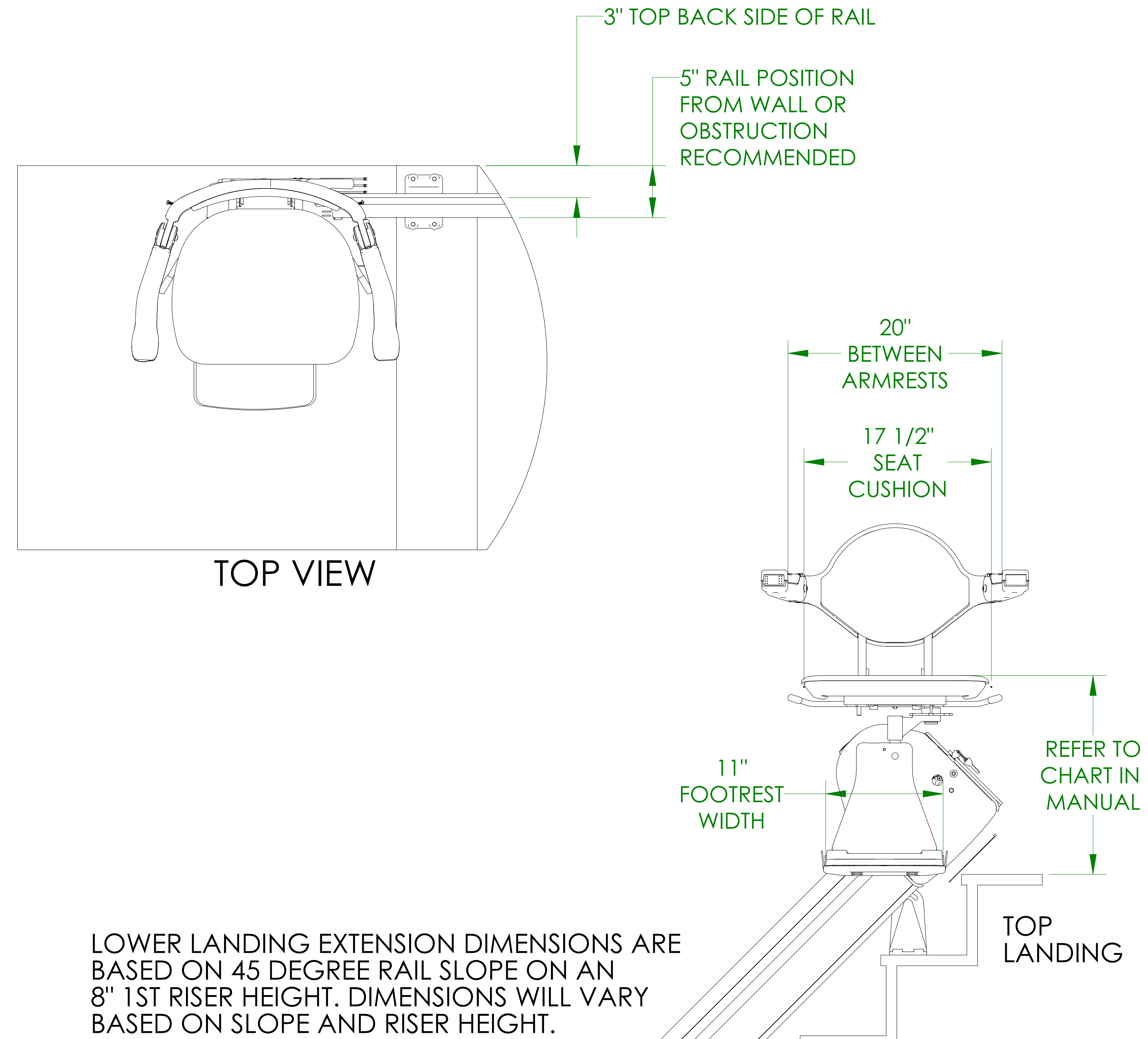

LOWER LANDING EXTENSION DIMENSIONS ARE
BASED ON 45 DEGREE RAIL SLOPE ON AN
8" 1ST RISER HEIGHT. DIMENSIONS WILL VARY
BASED ON SLOPE AND RISER HEIGHT.

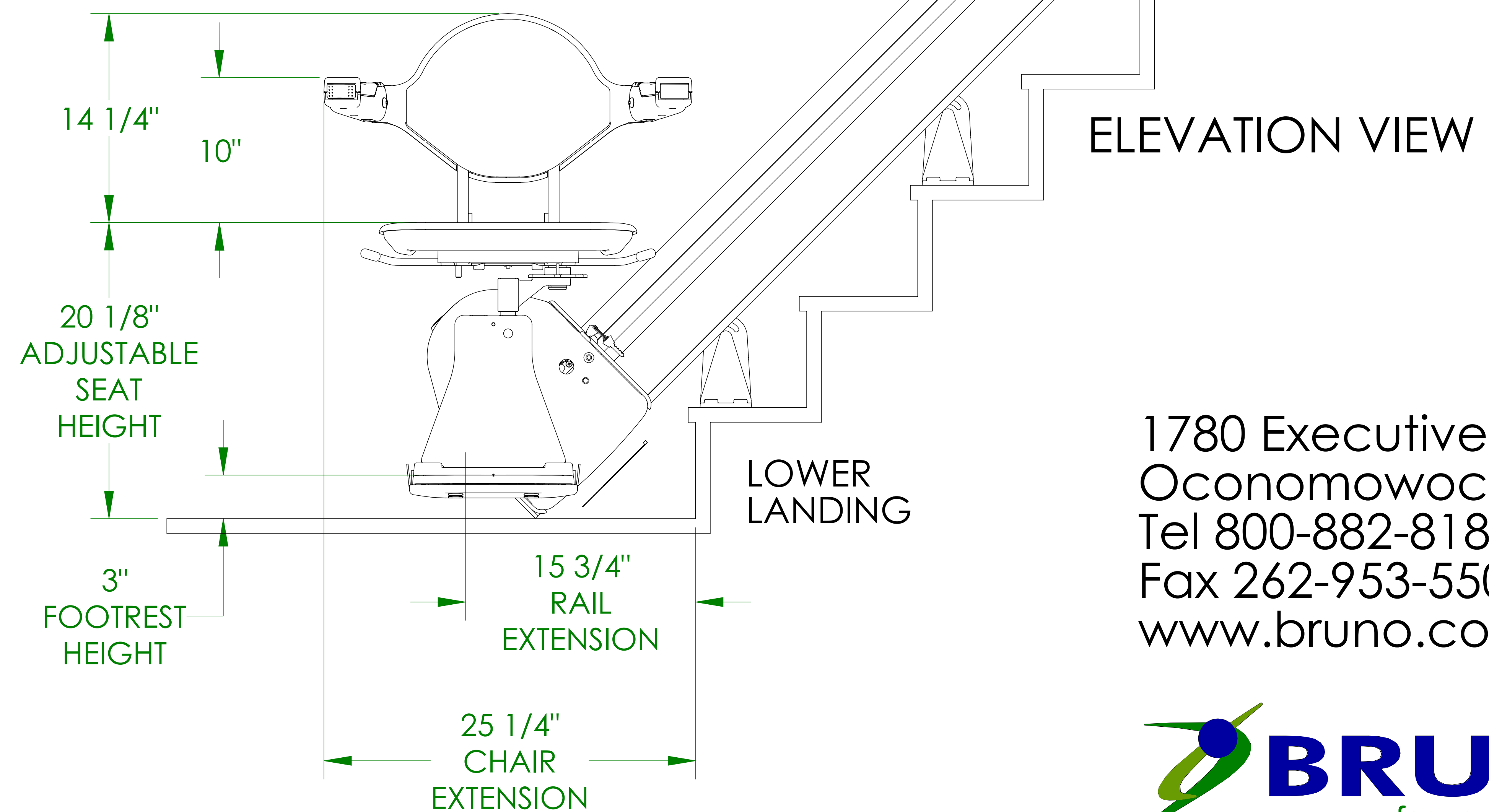

1780 Executive Drive
Oconomowoc, WI 53066
Tel 800-882-8181
Fax 262-953-5501
www.bruno.com



©Bruno Independent Living Aids, Inc.

ILS-01345
SHEET 1 OF 3
REV. 1 (6456)(9/01/17)(BHM)

SRE-3000

DISTANCE FROM WALL - SEAT SWIVELED

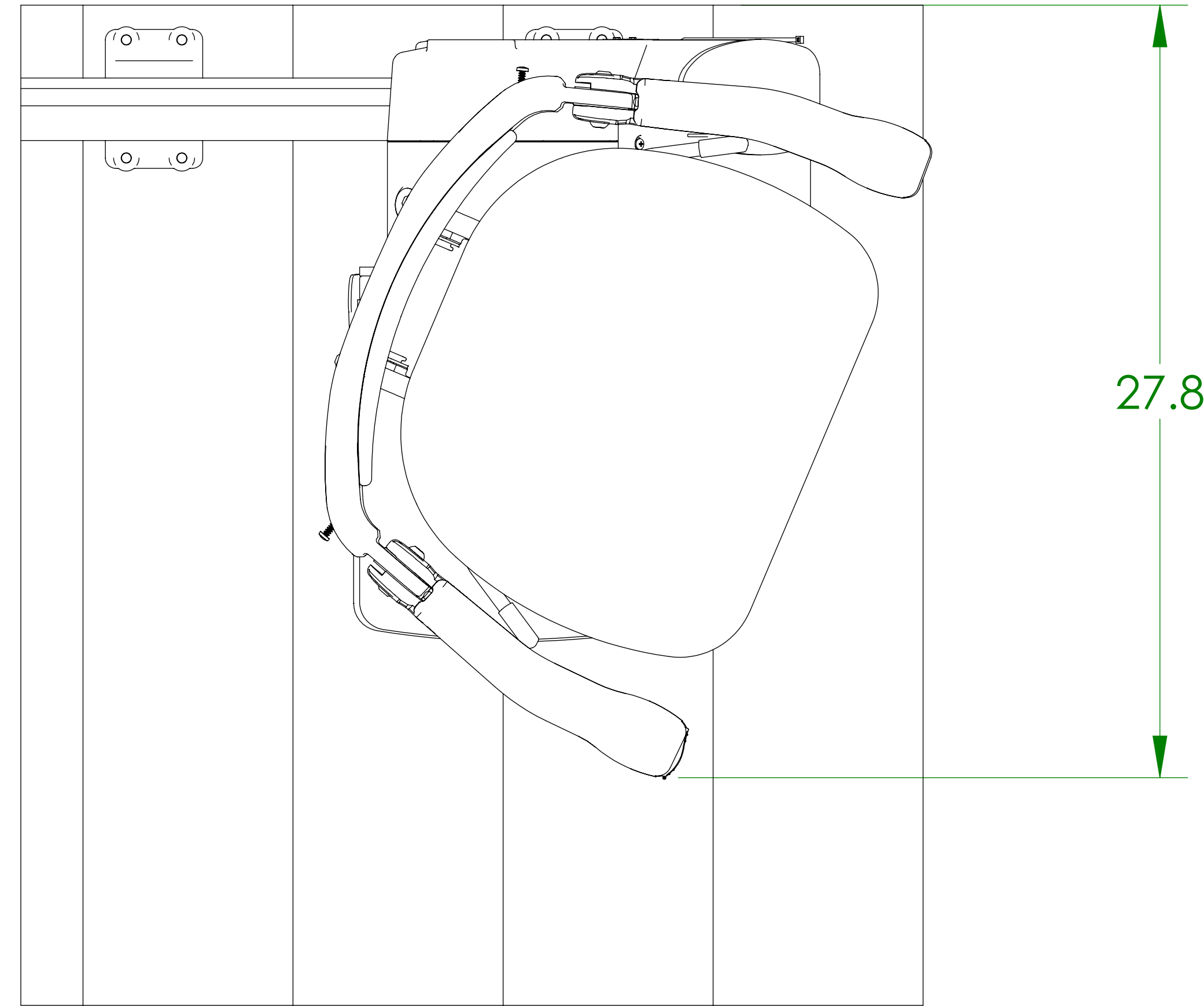

SEAT SWIVELED 67°

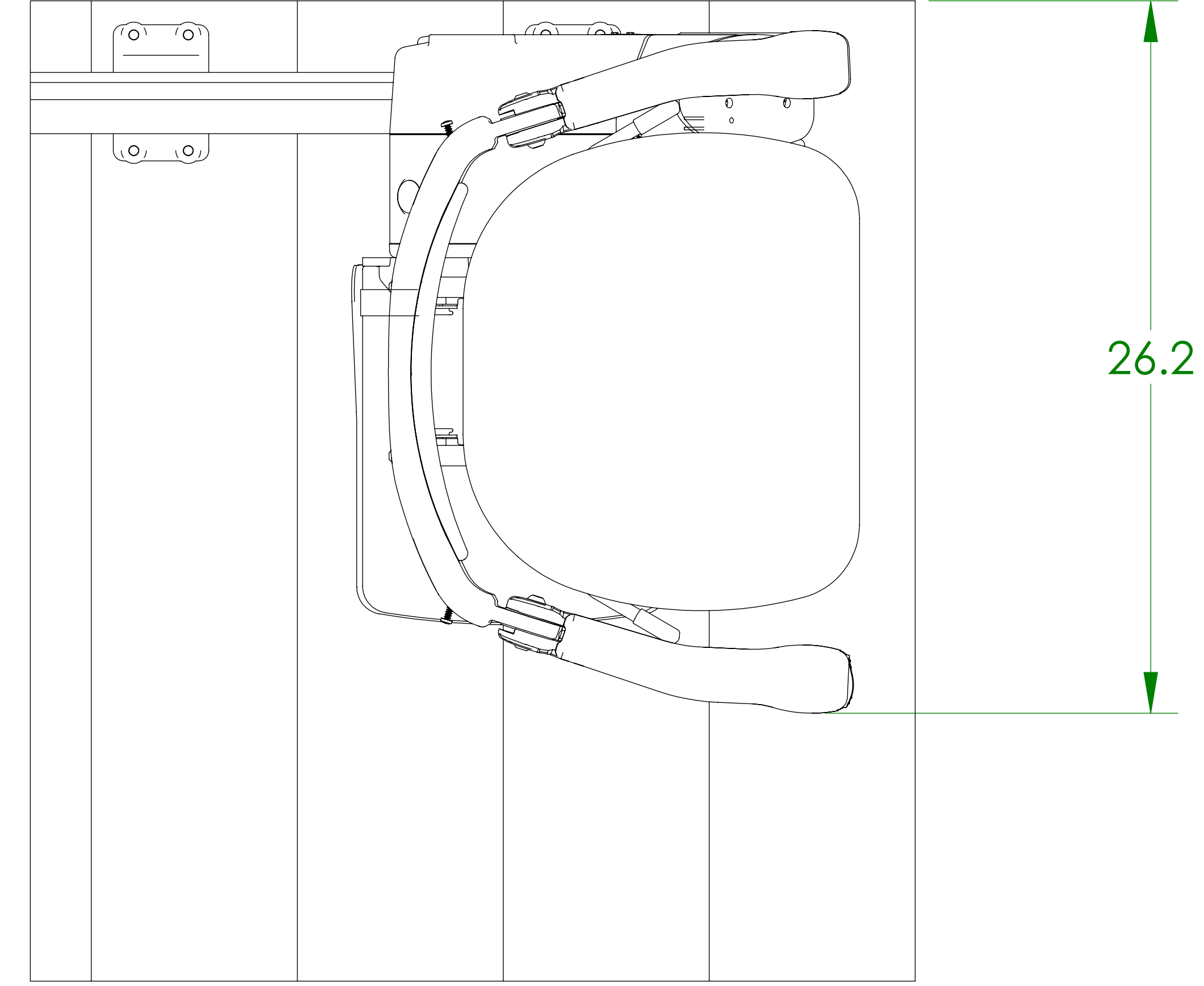

SEAT SWIVELED 90°

1780 Executive Drive
Oconomowoc, WI 53066
Tel 800-882-8181
Fax 262-953-5501
www.bruno.com

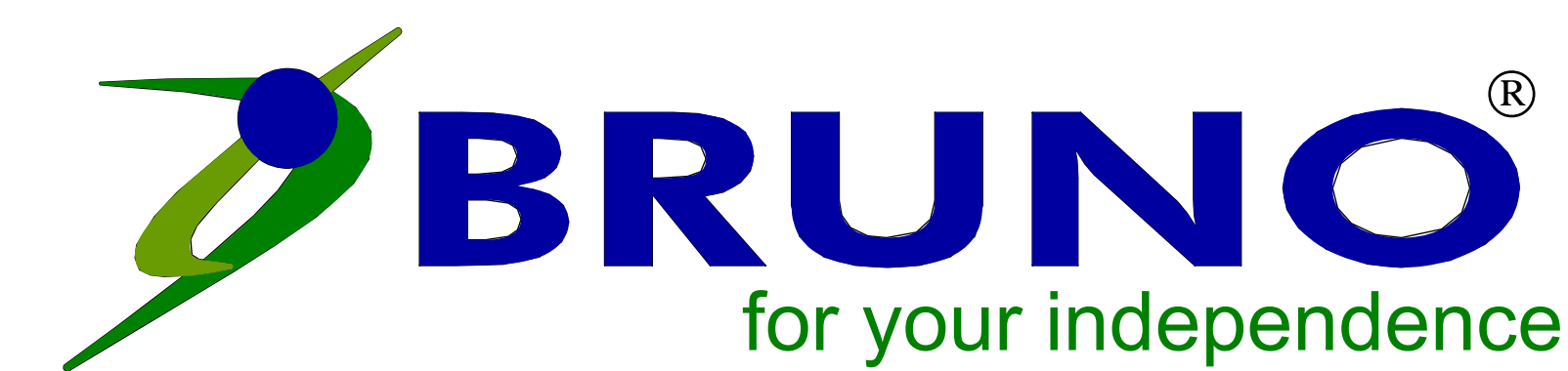

©Bruno Independent Living Aids, Inc.

SRE-3000 FOLDING RAIL

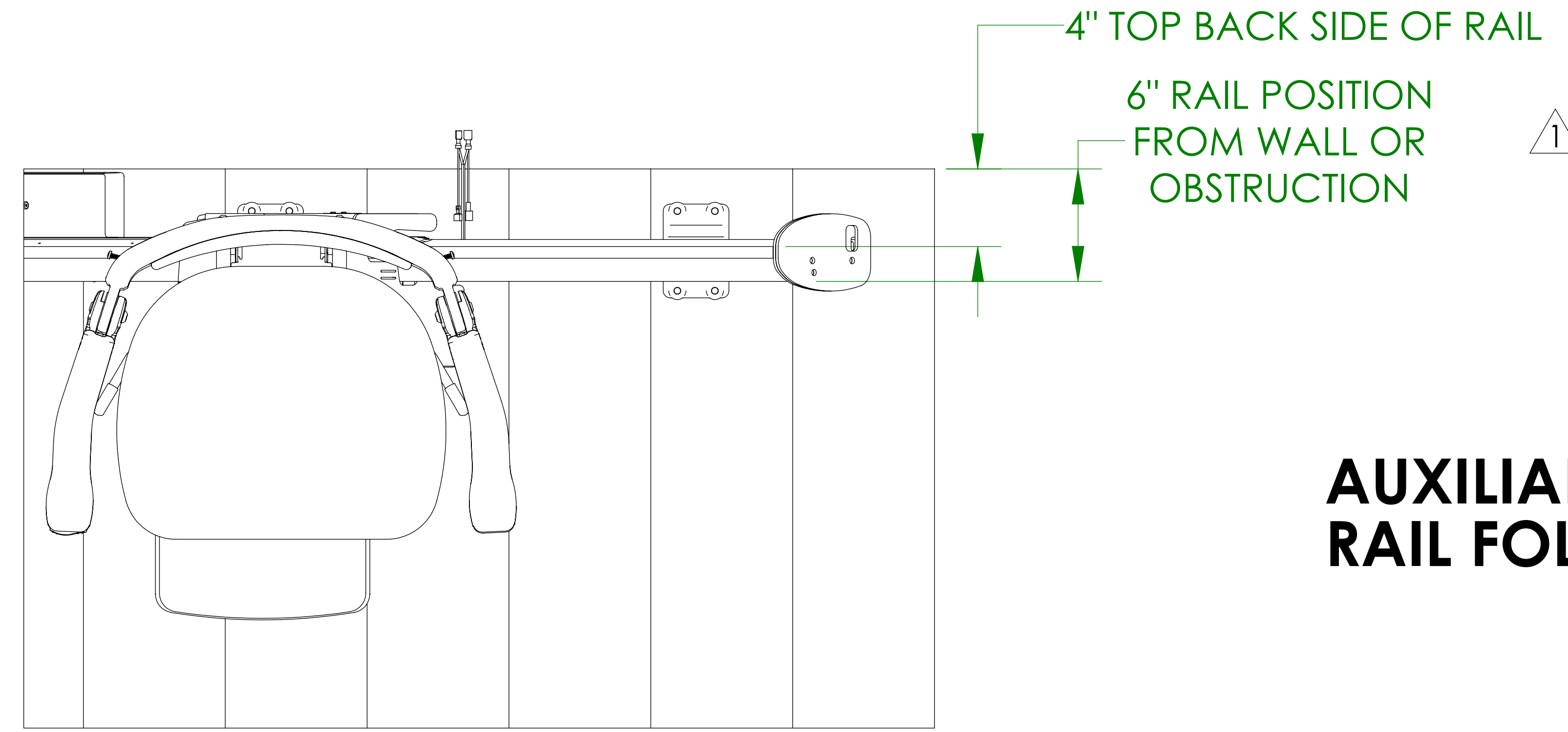

TOP VIEW

AUXILIARY ELEVATION VIEW
RAIL FOLDED UP POSITION

AUXILIARY ELEVATION VIEW
RAIL FOLDED DOWN POSITION

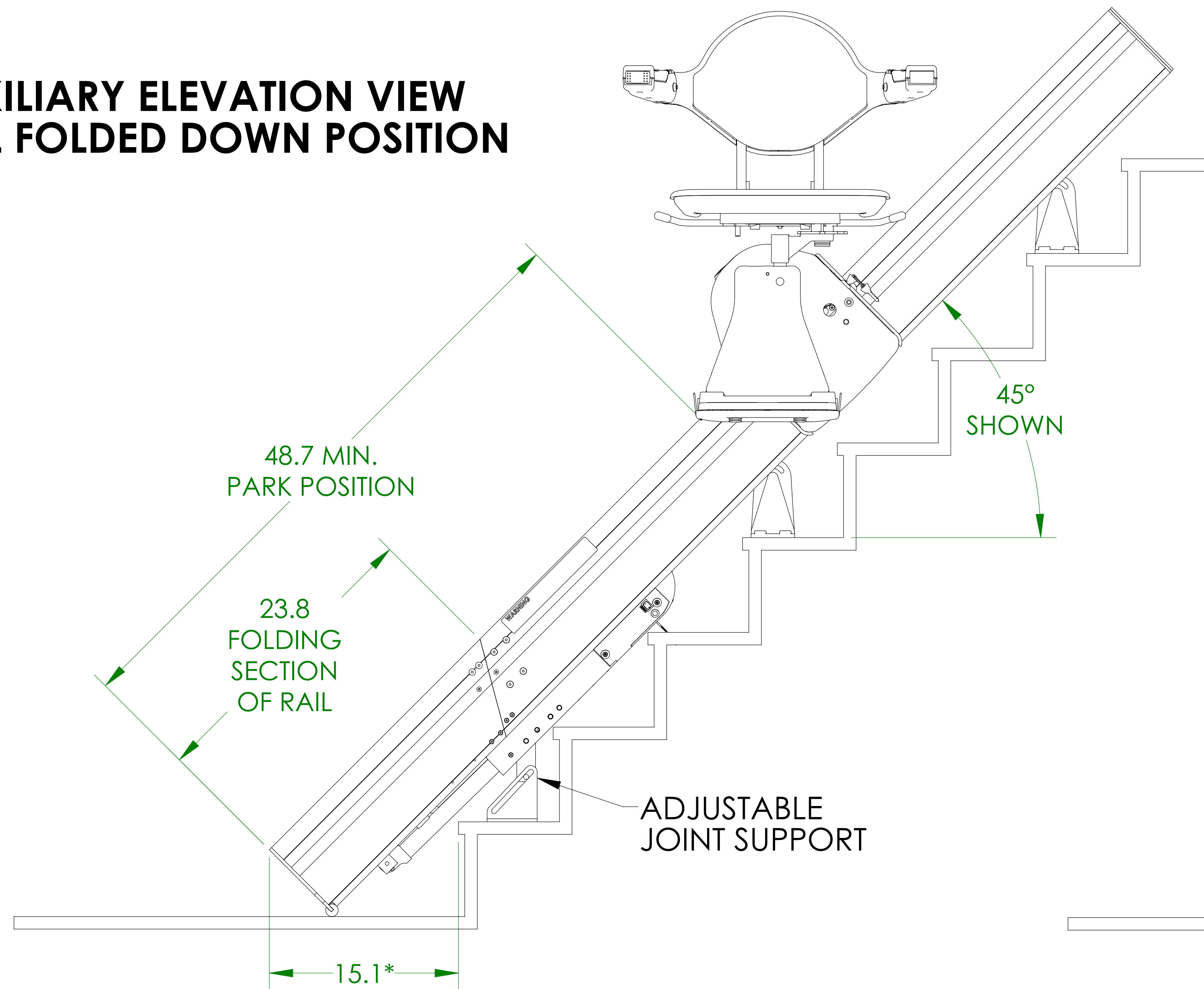

CARRIAGE
PARK
POSITION

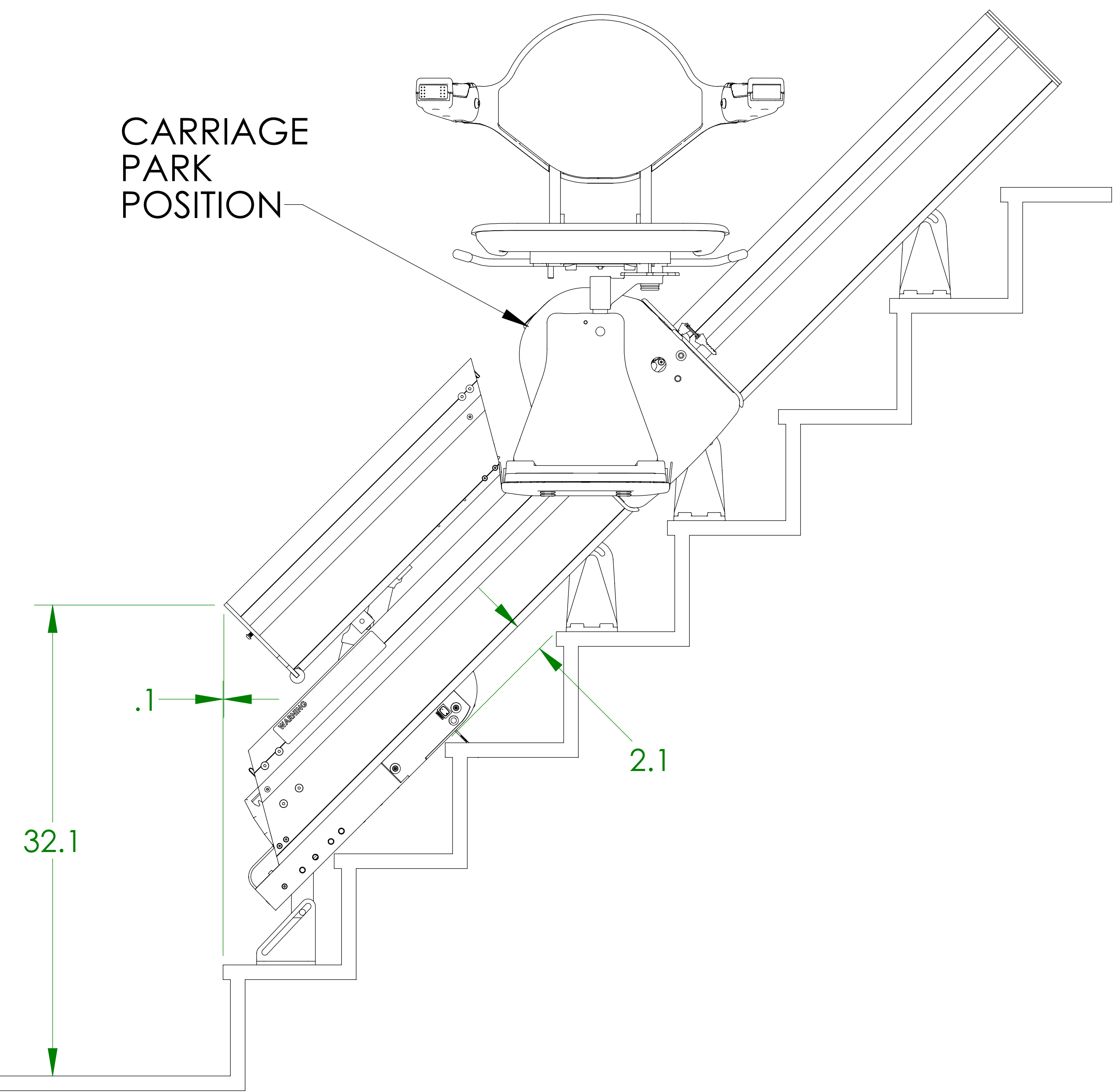

*LOWER LANDING EXTENSION DIMENSIONS ARE BASED ON 45° RAIL SLOPE AND 8" RISER HEIGHT. DIMENSIONS WILL VARY BASED ON SLOPE AND RISER HEIGHT.

1780 Executive Drive
Oconomowoc, WI 53066
Tel 800-882-8181
Fax 262-953-5501
www.bruno.com

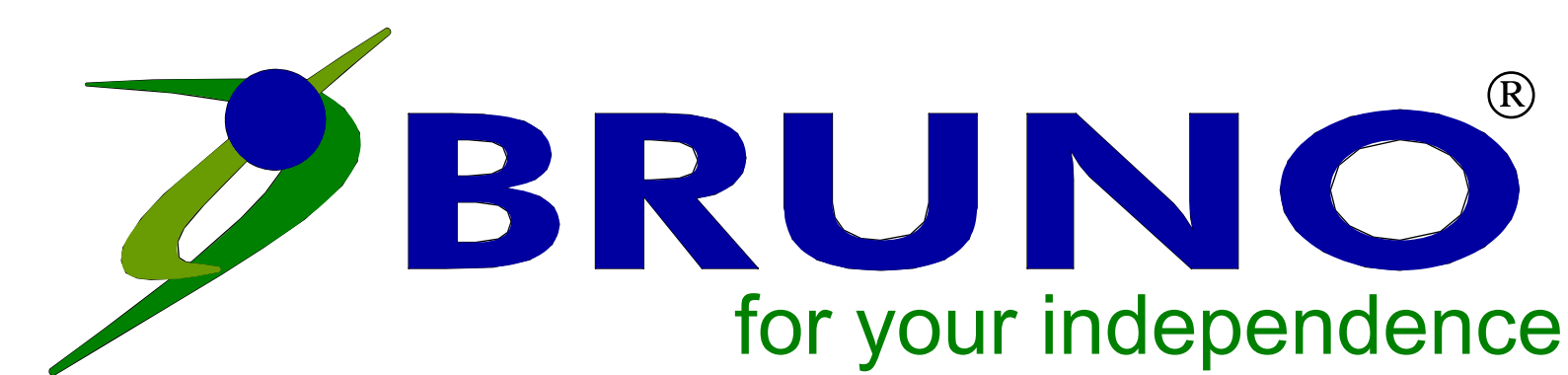

©Bruno Independent Living Aids, Inc.